

5.25", Steel Frame
1" PESVW Voice Coil, Aluminum Former
Paper Cone, Rubber Surround
Ferrite Magnet Motor System

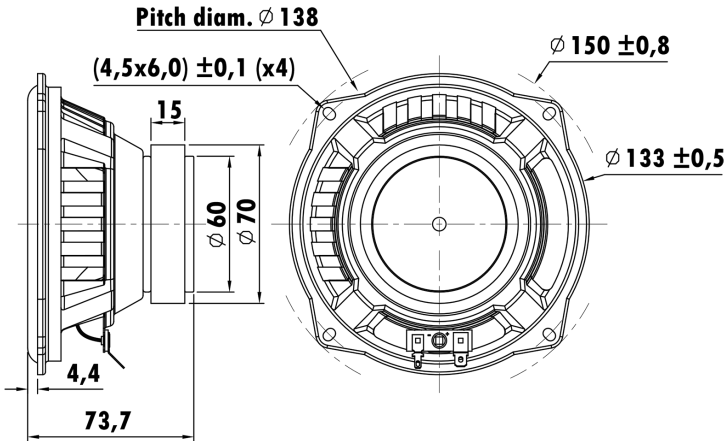

T-S Parameters

Resonance frequency [fs]	82.8 Hz
Mechanical Q factor [Qms]	3.421
Electrical Q factor [Qes]	1.025
Total Q factor [Qts]	0.788
Force factor [Bl]	4.389 Tm
Mechanical resistance [Rms]	2.394 kg/s
Moving mass [Mms]	15.746 g
Compliance [Cms]	0.235 mm/N
Effective diaph. diameter [D]	114 mm
Effective piston area [Sd]	102.07 cm ²
Equivalent volume [Vas]	3.2263 l
Sensitivity (2.83V/1m)	87 dB
Ratio Bl/√Re	3.15 N/√W
Ratio fs/Qts	105 Hz

Electrical Data

Nominal impedance [Zn]	3 Ω
Minimum impedance [Zmin]	2.980 Ω
Maximum impedance [Zo]	9.296 Ω
DC resistance [Re]	2.41 Ω
Voice coil inductance [Le]	0.344 mH

Power Handling

100h RMS noise test (IEC 18.4)	60 W
Long-term max power (IEC 18.2)	- W

Voice Coil & Magnet Data

Voice coil diameter	25.4 mm
Voice coil height	8.4 mm
Voice coil layers	4
Height of gap	4 mm
Linear excursion	± 2.2 mm
Max mech. excursion	± - mm
Unit weight	0.5545 kg

